

Spare parts list

Trowel

	Valid from serial number
G610 E (QP)	BGB52000001
G610 E (QP)	BGF0000001
G610 E (TP)	BGB52000001
G610 E (TP)	BGF0000001

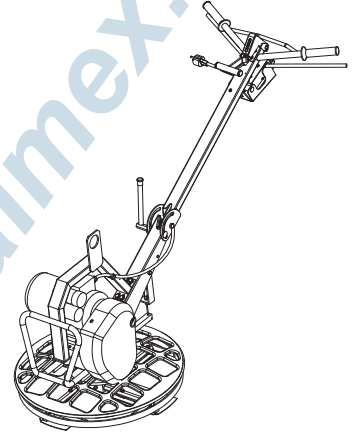



DALMEX

TREMIX®

www.dalmex.net

www.dalmex.net

www.dalmex.net

www.dalmex.net

Contents

General information.....	5
Spare parts list.....	6
Handle, quick pitch.....	6
Handle, twist pitch.....	8
Electric motor installation.....	10
Power transmission.....	12
Support and lifting device.....	14
Electric equipment.....	16
Protective ring.....	18
Blade assembly.....	20
Labels, quick pitch.....	22
Labels, twist pitch.....	24
Accessories.....	26
Consumables.....	26
Transport device.....	28
Kits.....	30
Maintenance kit (yearly recommend).....	30
Wiring diagram.....	31



DALMEX

TREMIX®

www.dalmex.net

www.dalmex.net

www.dalmex.net

www.dalmex.net

General information

This spare parts list applies to the following:

Part number	Description
3382 0001 29	Trowel G610 E (QP)
3382 0001 31	Trowel G610 E (TP)

Use only authorized parts. Any damage or malfunction caused by the use of unauthorized parts is not covered by Warranty or Product Liability.

Any unauthorized use or copying of the contents or any part thereof is prohibited. This applies in particular to trademarks, model denominations, part numbers, and drawings.

Instructions for use

This spare parts list contains no safety regulations and is merely intended to assist in the ordering of spare parts.

For information about operating, servicing, or repairing, the relevant Safety and operating instructions must be consulted at all costs.

Please observe the safety instructions listed in the relevant Safety and operating instructions!

Spare parts list

Handle, quick pitch

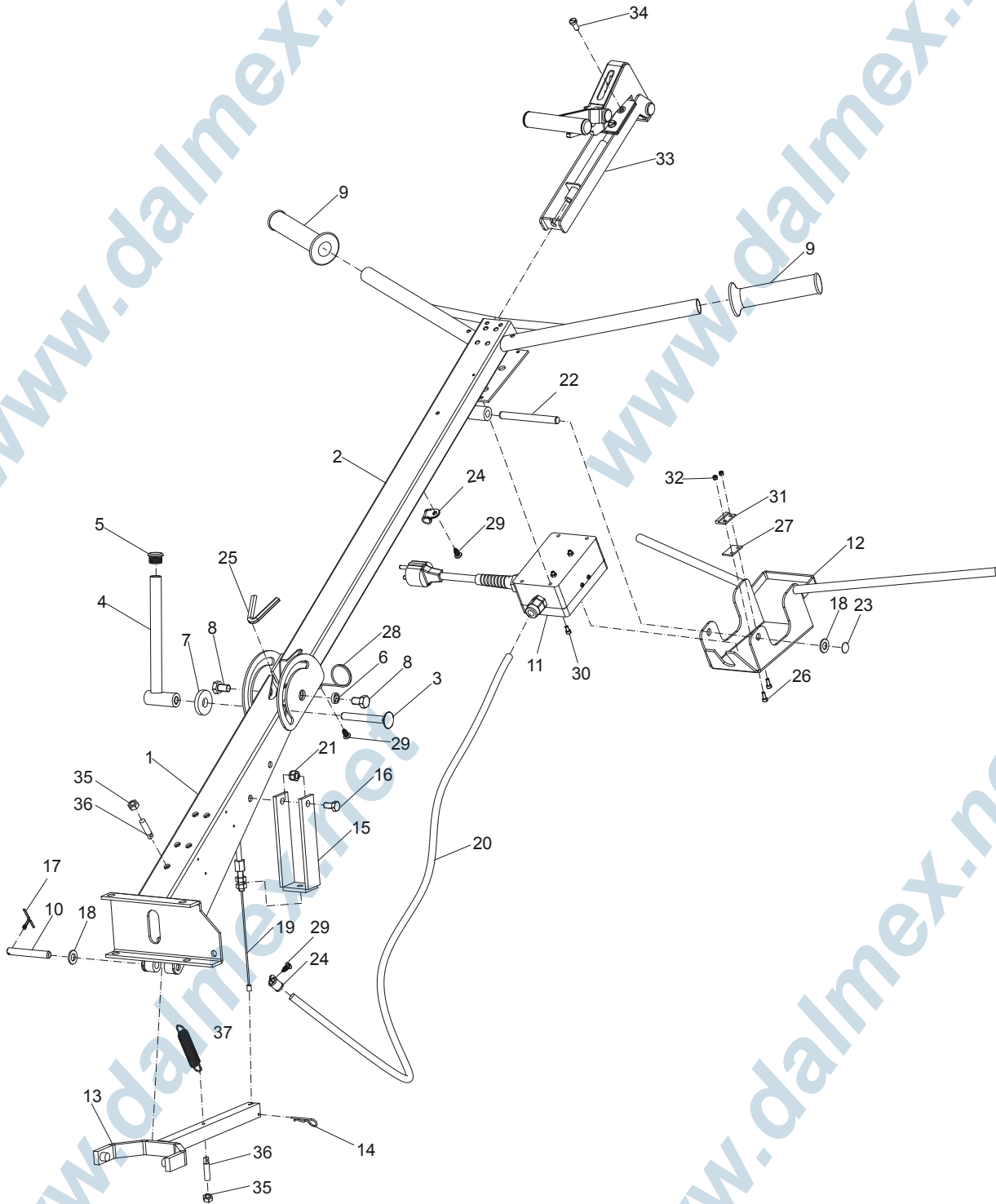

No.	Description	Remark	Quantity	Part number
1	Handle bracket		1	3382 0109 39
2	Handle upper part		1	3382 0112 22
3	Square neck bolt		1	0226 9915 25
4	Locking lever		1	4700 0490 51
5	Tube plug		1	4700 0028 16
6	Spacer sleeve		2	4700 0490 52
7	Washer	12 x 6 mm 0.47 x 0.24 in.	1	-
8	Screw	M10 x 16 mm	2	-
9	Rubber handle		2	4700 0012 13
10	Shaft		1	4700 0478 60
11	Control box		1	4700 0331 01
12	Security bracket		1	3382 0109 44
13	Fork		1	4700 0330 63
14	Locking clip		1	0111 1686 06
15	Bow		1	4700 0489 86
16	Screw	M8 x 16 mm 8.8	2	-
17	Split pin	3.2 x 28 mm 0.13 x 1.1 in.	2	0111 1252 02
18	Washer	10 x 2 mm 0.40 x 0.08 in.	4	-
19	Adjusting wire		1	4700 0490 00
20	Wire		1	4700 0010 19
21	Lock nut	M8	2	-
22	Clevis pin		1	3382 0111 80
23	Locking washer		2	4700 0028 17
24	Pipe clamp		2	0346 1000 49
25	Edge protection		1	4700 0026 27
26	Screw	M4 x 10 mm	2	-
27	Isolating washer		1	4700 0479 50
28	Wire holder		1	4700 0464 31
29	Tapping screw		3	0226 3139 03
30	Screw	M4 x 8 mm	4	-
31	Magnet		1	4700 0033 14
32	Lock nut	M4	2	-
33	Quick pitch		1	4700 0330 85
34	Screw	M6 X 14 mm	4	-
35	Nut		2	-
36	Bracket		2	4700 0001 68
37	Spring		1	3382 0112 39

Handle, twist pitch

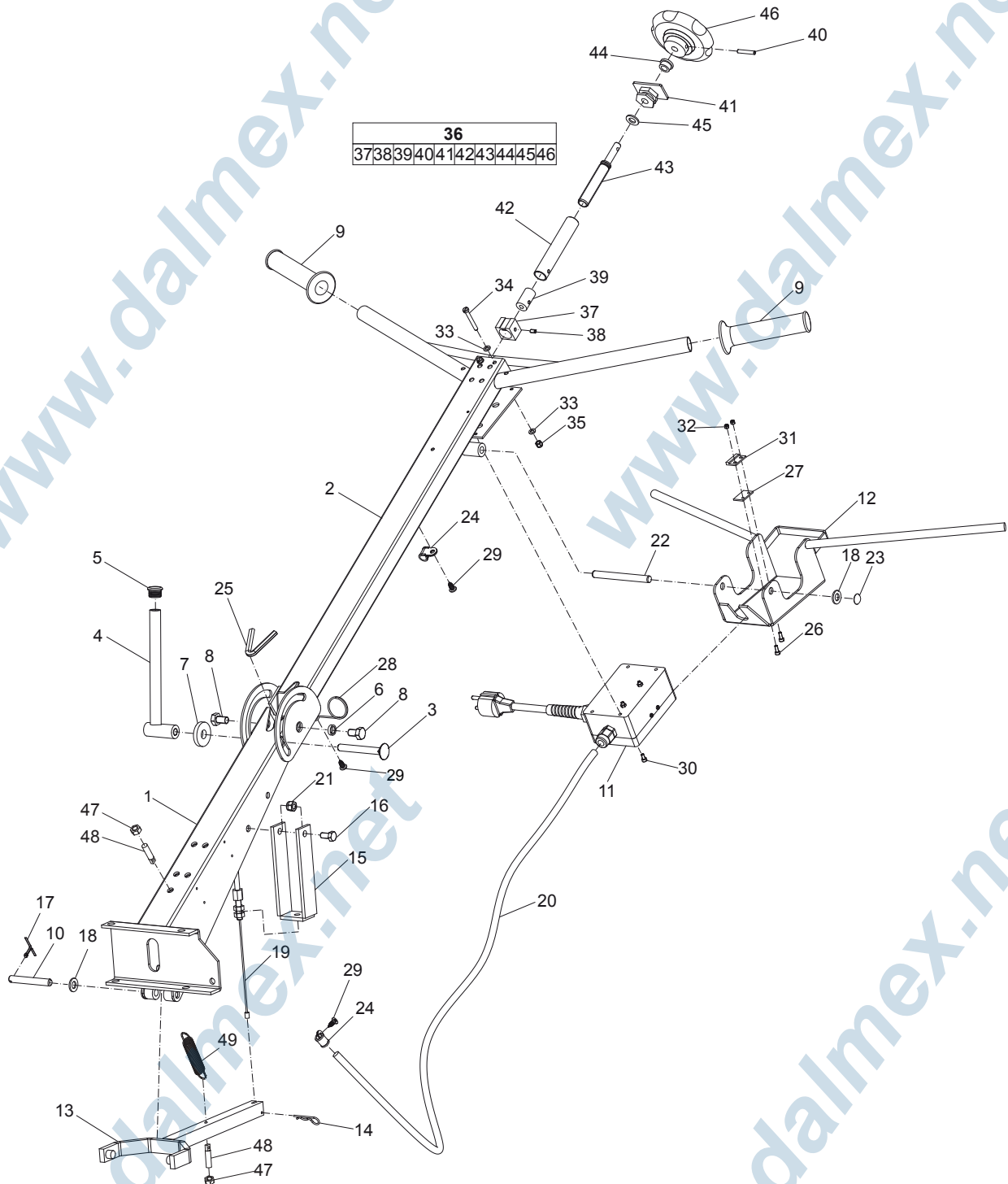

No.	Description	Remark	Quantity	Part number
1	Handle bracket		1	3382 0109 39
2	Handle upper part		1	3382 0112 22
3	Square neck bolt		1	0226 9915 25
4	Locking lever		1	4700 0490 51
5	Tube plug		1	4700 0028 16
6	Spacer sleeve		2	4700 0490 52
7	Washer	12 x 6mm 0.47 x 0.24 in.	1	-
8	Screw	M10 x 16 mm	2	-
9	Rubber handle		2	4700 0012 13
10	Shaft		1	4700 0478 60
11	Control box		1	4700 0331 01
12	Security bracket		1	3382 0109 44
13	Fork		1	4700 0330 63
14	Locking clip		1	0111 1686 06
15	Bow		1	4700 0489 86
16	Screw	M8 x 16 mm	2	-
17	Split pin	3.2 x 2.8 mm 0.13 x 0.11 mm	2	0111 1252 02
18	Washer	10 x 2 mm 0.40 x 0.08 in.	4	-
19	Adjusting wire		1	4700 0490 00
20	Wire		1	4700 0010 19
21	Lock nut	M8	2	-
22	Clevis pin		1	3382 0111 80
23	Locking washer		2	4700 0028 17
24	Pipe clamp		2	0346 1000 49
25	Edge protection		1	4700 0026 27
26	Screw	M4 x 10 mm	2	-
27	Isolating washer		1	4700 0479 50
28	Wire holder		1	4700 0464 31
29	Tapping screw		3	0226 3139 03
30	Screw	M4 x 8 mm	4	-
31	Magnet		1	4700 0033 14
32	Lock nut	M4	2	-
33	Washer	5.3 x 10 x 1 mm 0.21 x 0.40 x 0.04 in.	4	-
34	Screw	M5 x 40 mm	2	-
35	Lock nut	M5	2	-
36(37-46)	Blade adjuster, complete		1	3382 1000 61
37	Guiding		1	-
38	Screw	M5 x 8 mm	2	-
39	Wire lock		1	-
40	Spring pin	5 x 30 mm 0.20 x 1.18 in.	1	-
41	Bearing support		1	-
42	Adjusting nut		1	-
43	Adjusting screw		1	-
44	Flange bearing		1	-
45	Washer	10 x 2 mm 0.40 x 0.08 in.	1	-
46	Knob		1	-
47	Nut		2	-
48	Bracket		1	4700 0001 68
49	Spring		1	3382 0112 39

Electric motor installation

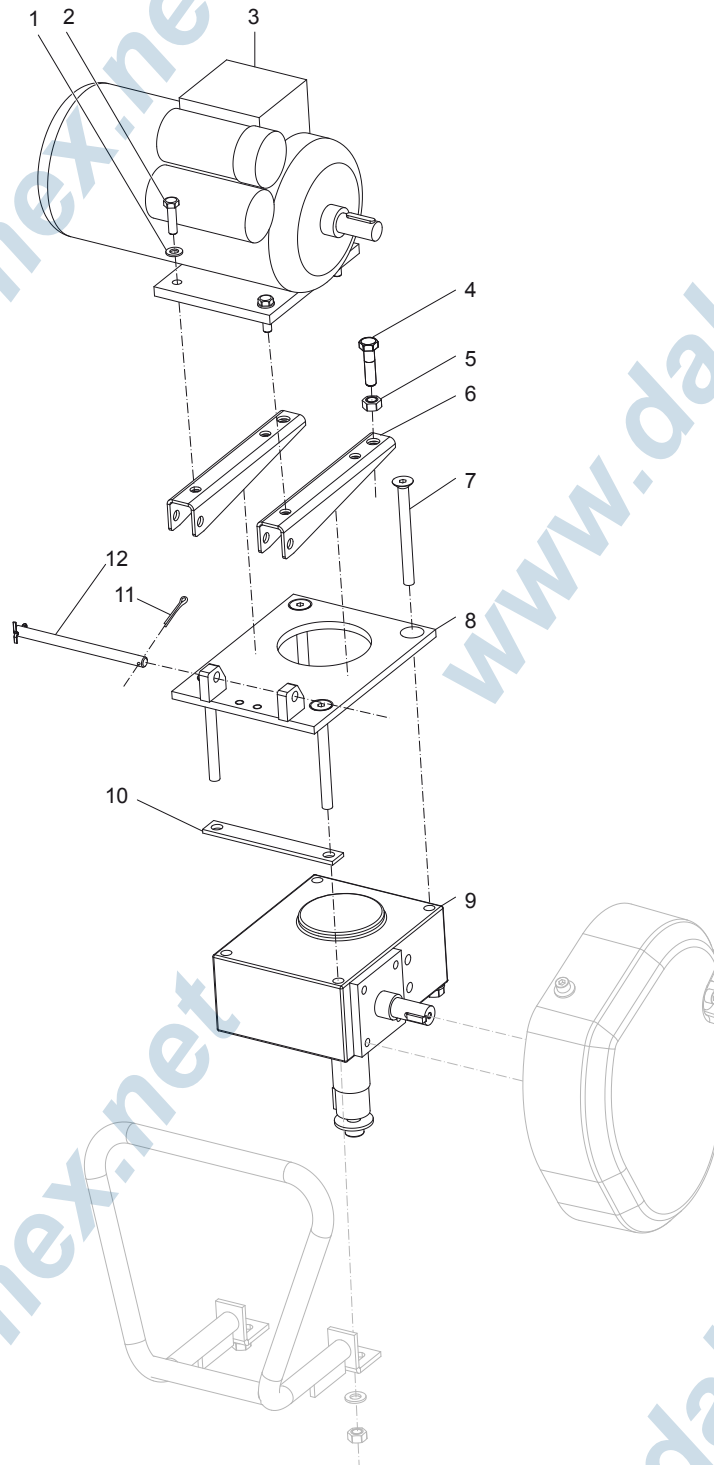

No.	Description	Remark	Quantity	Part number
1	Washer	8.4 x 16 x 1.6 mm 0.33 x 0.63 x 0.06 in.	4	-
2	Screw	M8 x 30 mm	4	-
3	Electric motor		1	4700 0037 11
4	Screw	M10 x 40 mm	2	-
5	Nut	M10 mm	2	-
6	Bracket		2	3382 0106 08
7	Screw	10 x 110 mm 0.40 x 4.33 in.	4	-
8	Motor plate		1	3382 0109 37
9	Gear box		1	4700 0028 58
10	Holder		1	3382 0105 57
11	Split pin	3.2 x 20 mm 0.13 x 0.79 in.	2	0111 1279 03
12	Clevis pin		1	3382 0106 52

Power transmission

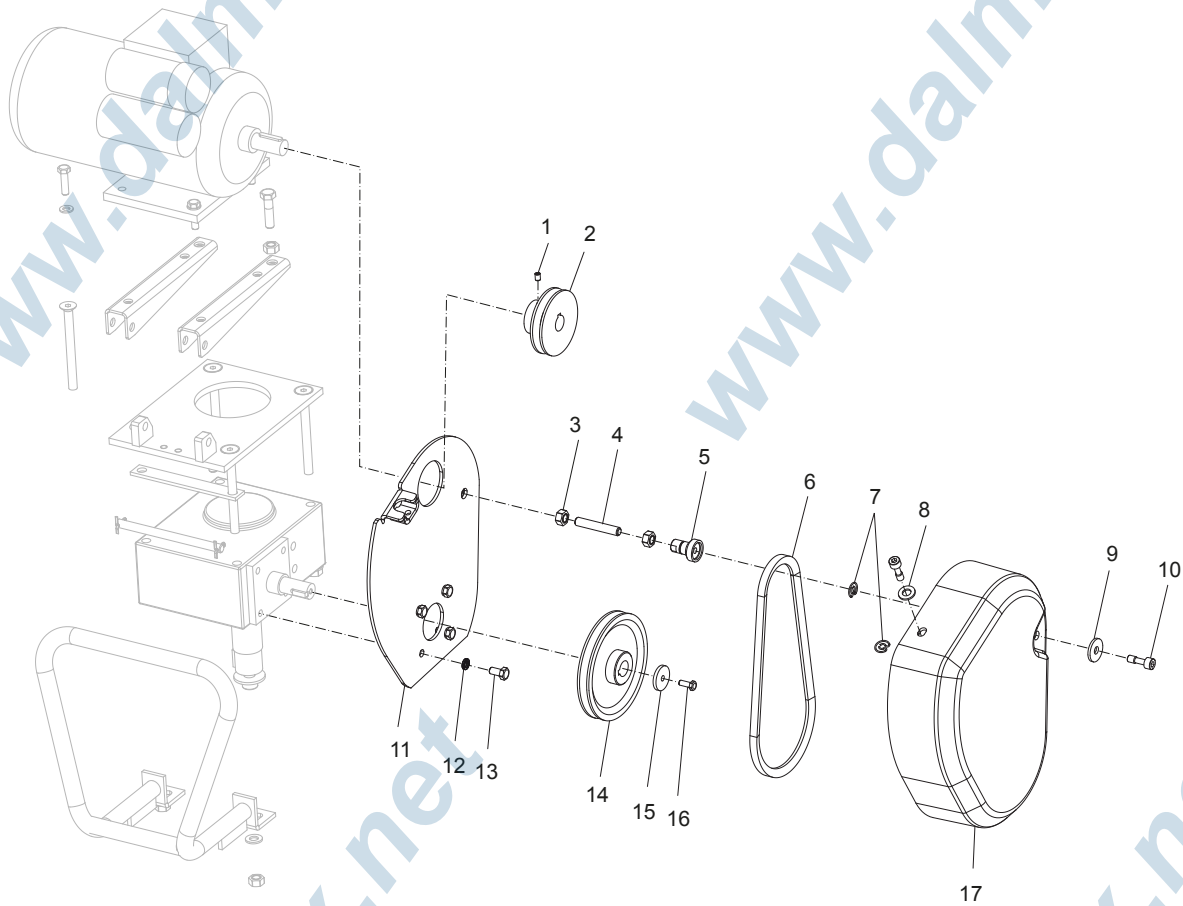

No.	Description	Remark	Quantity	Part number
1	Set screw	M6 x 8 mm	1	0196 1242 00
2	Pulley		1	4700 0490 30
3	Nut	M10	2	-
4	Threaded rod	M10 x 60 mm	1	0248 9980 43
5	Holder		1	4812 0602 74
6	V-belt	Lp = 670 mm	1	4700 0028 26
7	Lock spring		1	3382 0109 72
8	Washer	10.5 x 20 x 2 mm 0.41 x 0.79 x 0.08 in.	1	-
9	Washer	9 x 28 x 3 mm 0.35 x 1.10 x 0.12 in.	1	-
10	Captive screw		2	4812 0602 78
11	Holder		1	3382 0108 31
12	Spring washer	8.1 x 2 mm 0.32 x 0.08 in.	4	-
13	Hexagon head screw	M8 x 16 mm	4	-
14	Pulley		1	4700 0330 97
15	Washer	6.5 x 30 x 4 mm 0.26 x 1.18 x 0.16 in.	1	-
16	Hexagon head screw	M6 x 16 mm	1	-
17	Belt cover		1	3382 0109 42

Support and lifting device

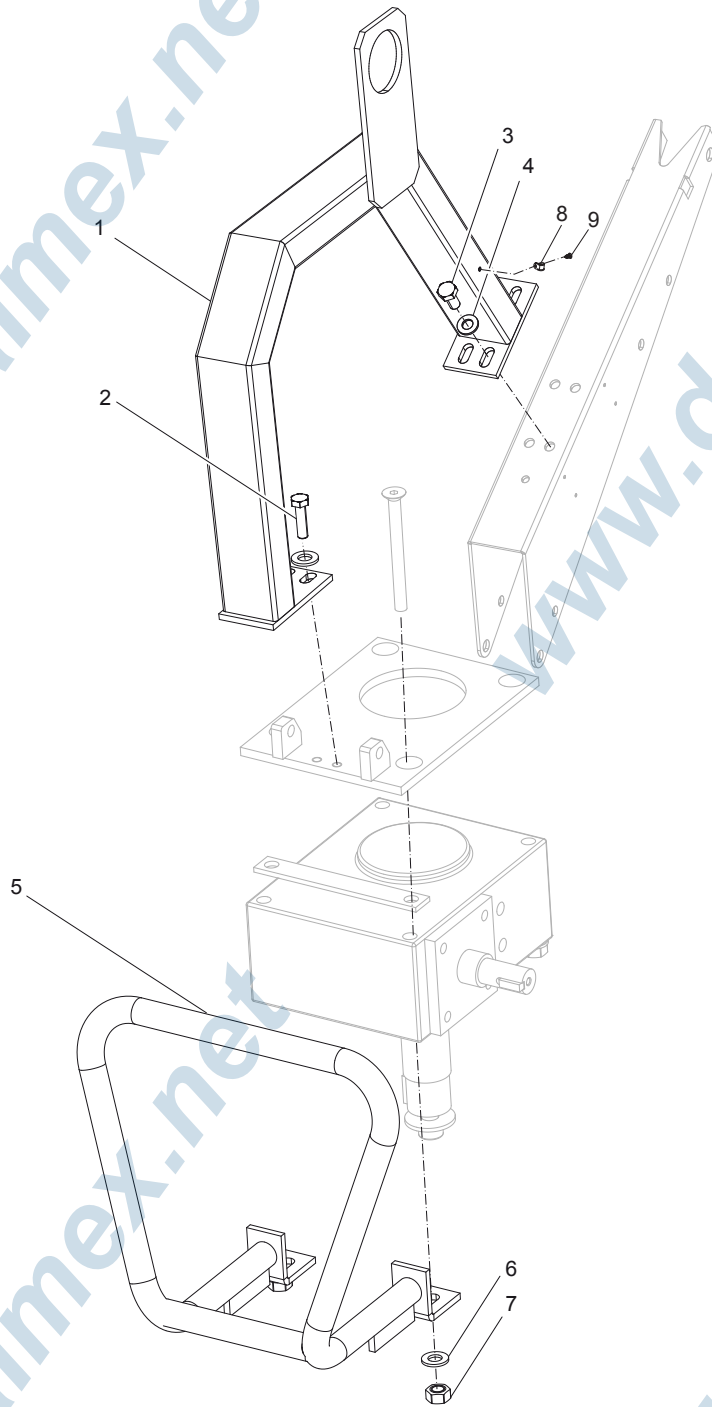

No.	Description	Remark	Quantity	Part number
1	Lifting hook		1	3382 0112 27
2	Screw	M8 x 30 mm	2	-
3	Screw	M8 x 16 mm	4	-
4	Washer	8.4 x 16 x 1.6 mm 0.33 x 0.63 x 0.06 in.	6	-
5	Support arch		1	3382 0104 62
6	Washer	10.5 x 20 x 2 mm 0.41 x 0.79 x 0.08 in.	2	-
7	Nut	M10	2	-
8	Pipe clamp		1	0346 1000 49
9	Tapping screw		1	0226 3139 03

www.dalmex.net

www.dalmex.net

Electric equipment

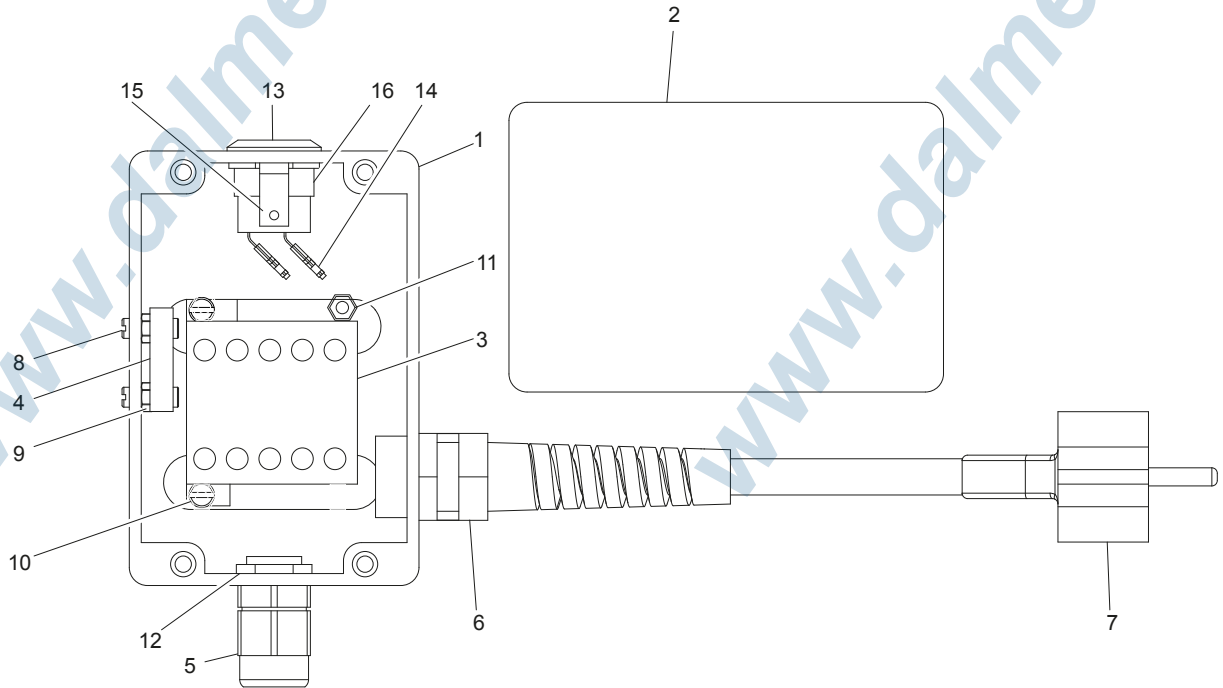

No.	Description	Remark	Quantity	Part number
1	Connection box		1	4700 0331 00
2	Lid		1	3382 0111 49
3	Connector		1	4700 0037 31
4	Magnet transmitter		1	4700 0033 13
5	Gland		1	4700 0038 99
6	Gland with bending protection		1	4700 0032 16
7	Hose with plug		1	4700 0036 27
8	Slotted screw	M3 x 12 mm	2	-
9	Lock nut	M3	2	-
10	Slotted screw	M4 x 16 mm	2	-
11	Hexagon nut	M4	4	-
12	Check nut		1	4700 0038 97
13	Button		1	4700 0037 38
14	Flat pin socket		2	4700 0036 44
15	Ground washer		1	4700 0491 70
16	Check nut		1	3382 0111 48

Protective ring

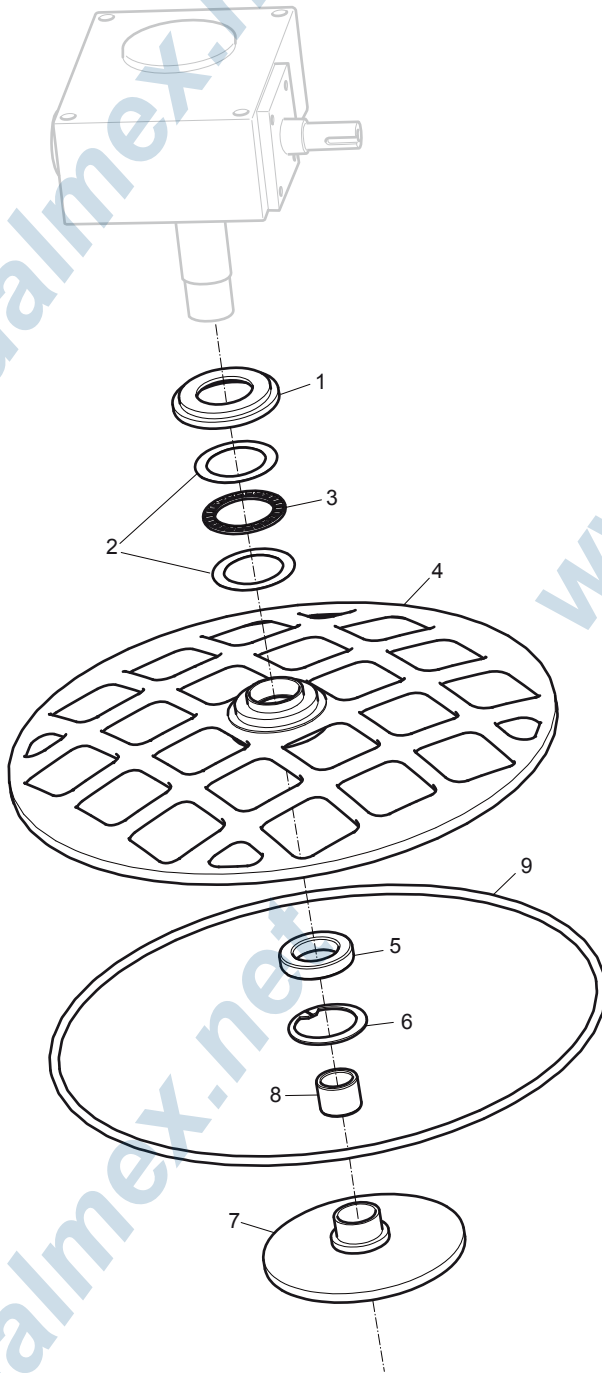

No.	Description	Remark	Quantity	Part number
1	Pressing sleeve	116 x 15 mm 4.57 x 0.60 in.	1	4700 0489 26
2	Thrust washer	AS 6590	2	4700 0001 66
3	Thrust bearing	AXK 6590	1	4700 0001 65
4	Protective cover		1	3382 0109 31
5	Ball bearing	6010 - 2RS1	1	4700 0001 15
6	Retaining ring	80 x 2.5 mm 3.15 x 0.10 in.	1	0335 2160 00
7	Pressure plate		1	4700 0330 90
8	Sleeve bearing		1	4700 0022 25
9	PVC ring	ø10 mm ø0.40 in.	1	4700 0490 57

www.dalmex.net

www.dalmex.net

Blade assembly

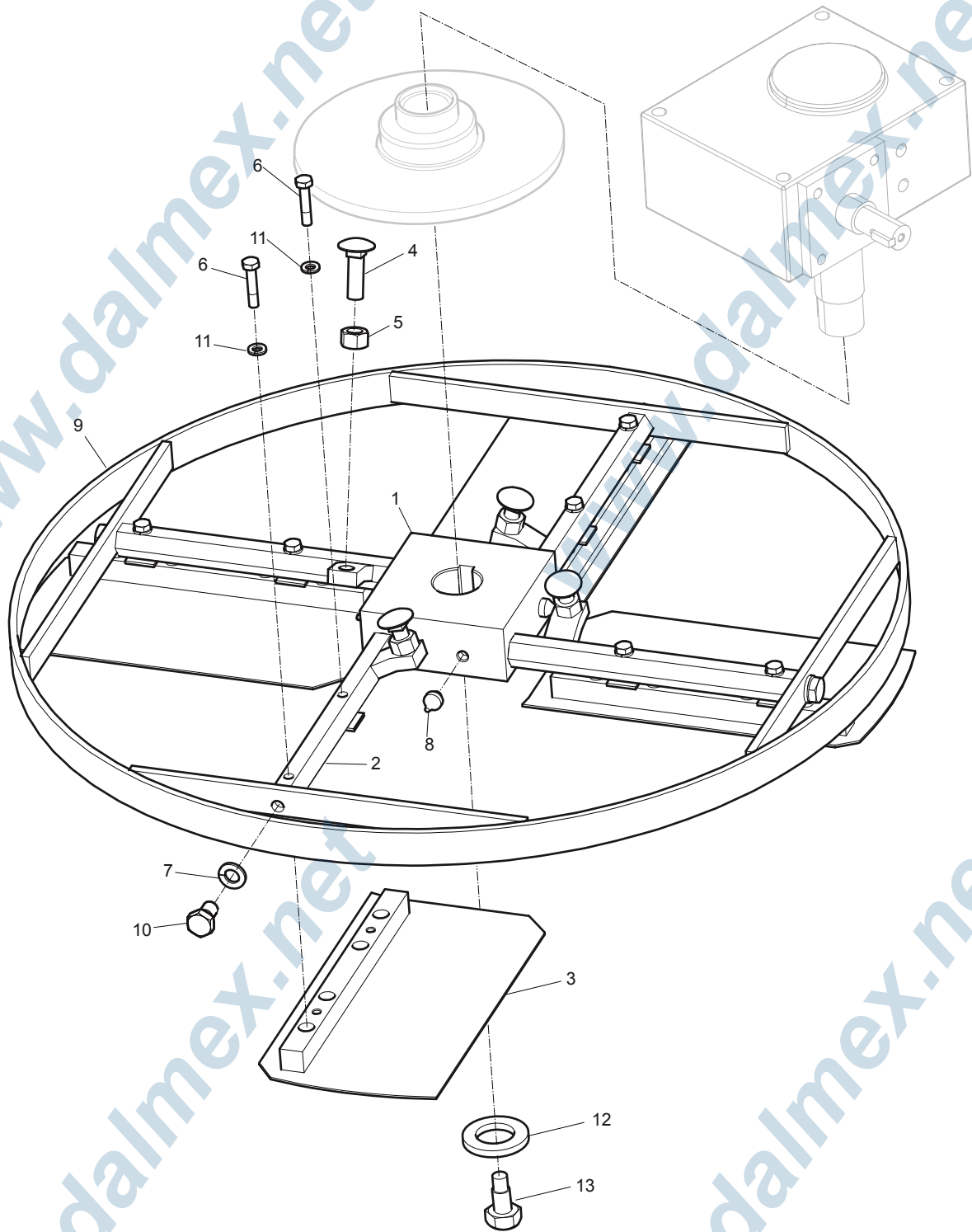

No.	Description	Remark	Quantity	Part number
1	Hub		1	4700 0330 26
2	Blade axle		4	4700 0330 27
3	Trowel blade		4	4700 0489 68
4	Square neck bolt	10 x 35 mm 0.40 x 1.38 in.	4	-
5	Nut	M10	4	-
6	Screw	M6 x 30 mm 8.8	8	-
7	Washer	10 x 16 mm 0.40 x 0.63 in.	4	-
8	Grease nipple		4	0544 1100 09
9	Blade ring		1	4700 0330 30
10	Screw	M10 x 16 mm	4	-
11	Washer	6 x 1.6 mm 0.24 x 0.06 in.	8	-
12	Washer	13 x 3 mm 0.51 x 0.12 in.	1	-
13	Screw	M12 x 30 mm	1	-

Labels, quick pitch

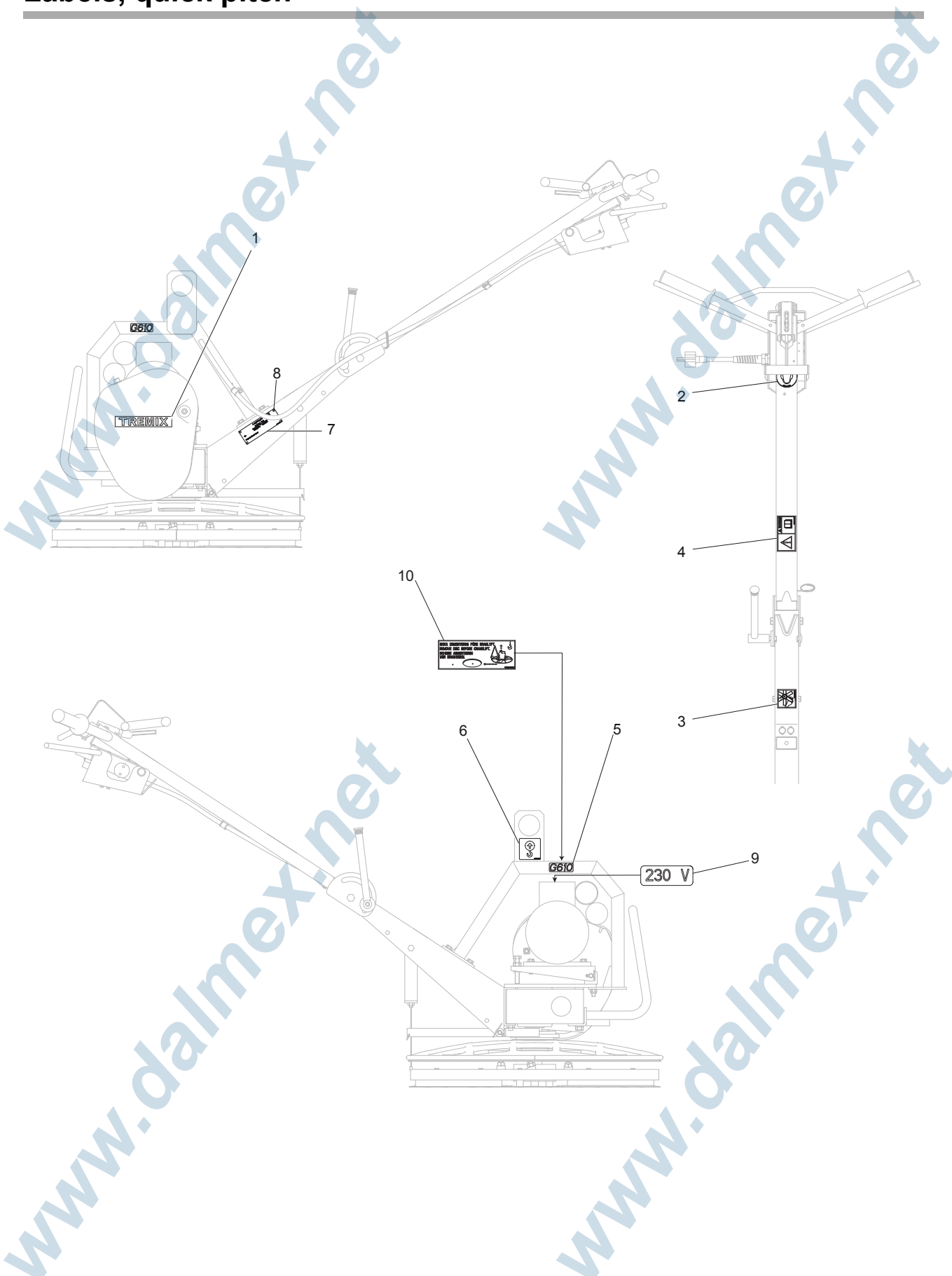

No.	Description	Remark	Quantity	Part number
1	Product label	"Tremix"	1	3382 0110 04
2	Label	Ear protection	1	3382 0109 00
3	Label	Cutting hazards	1	3382 0109 02
4	Safety label		1	3382 0108 99
5	Product label	G610	2	3382 0112 34
6	Label	Lift point	1	3382 0109 01
7	Data plate		1	-
8	Drive screw		4	-
9	Voltage label	230 V	1	4700 0439 85
10	Label	Remove disc	1	4700 0462 39

www.dalmex.net

www.dalmex.net

Labels, twist pitch

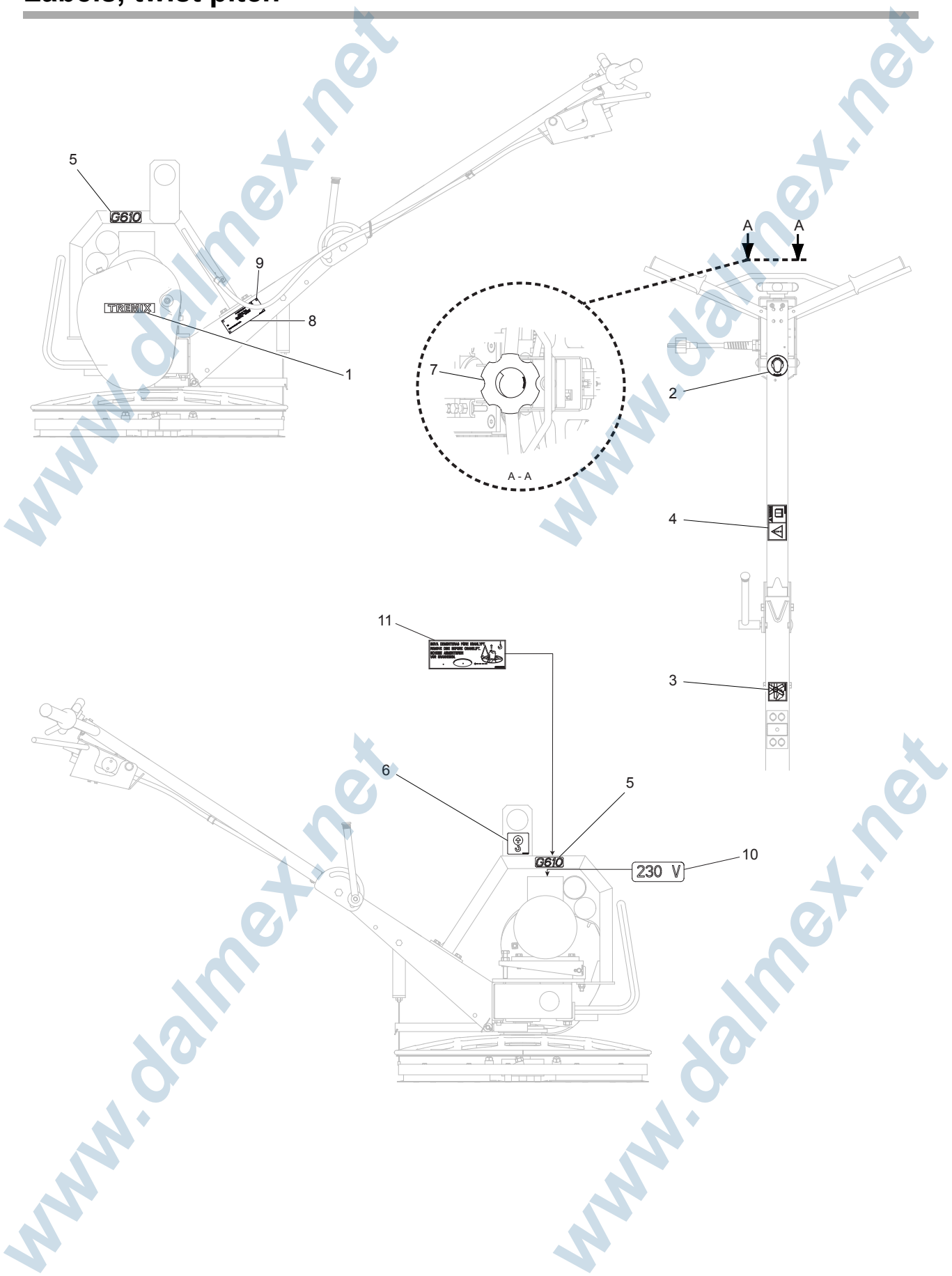

No.	Description	Remark	Quantity	Part number
1	Product label	"Tremix"	1	3382 0110 04
2	Label	Ear protection	1	3382 0109 00
3	Label	Cutting hazards	1	3382 0109 02
4	Safety label		1	3382 0108 99
5	Product label	G610	2	3382 0112 34
6	Label	Lift point	1	3382 0109 01
7	Label	Blade angle	1	4700 0459 02
8	Data plate		1	-
9	Drive screw		4	-
10	Voltage label	230 V	1	4700 0439 85
11	Label	Remove disc	1	4700 0462 39

www.dalmex.net

www.dalmex.net

Accessories

Consumables

Description	Remark	Quantity	Part number
Floating disc		1	4700 0330 81
Trowel blade	Bolt on/4 blades included	1	4700 0489 68

www.dalmex.net

www.dalmex.net

www.dalmex.net

www.dalmex.net

Transport device

Part number 3382 0105 72

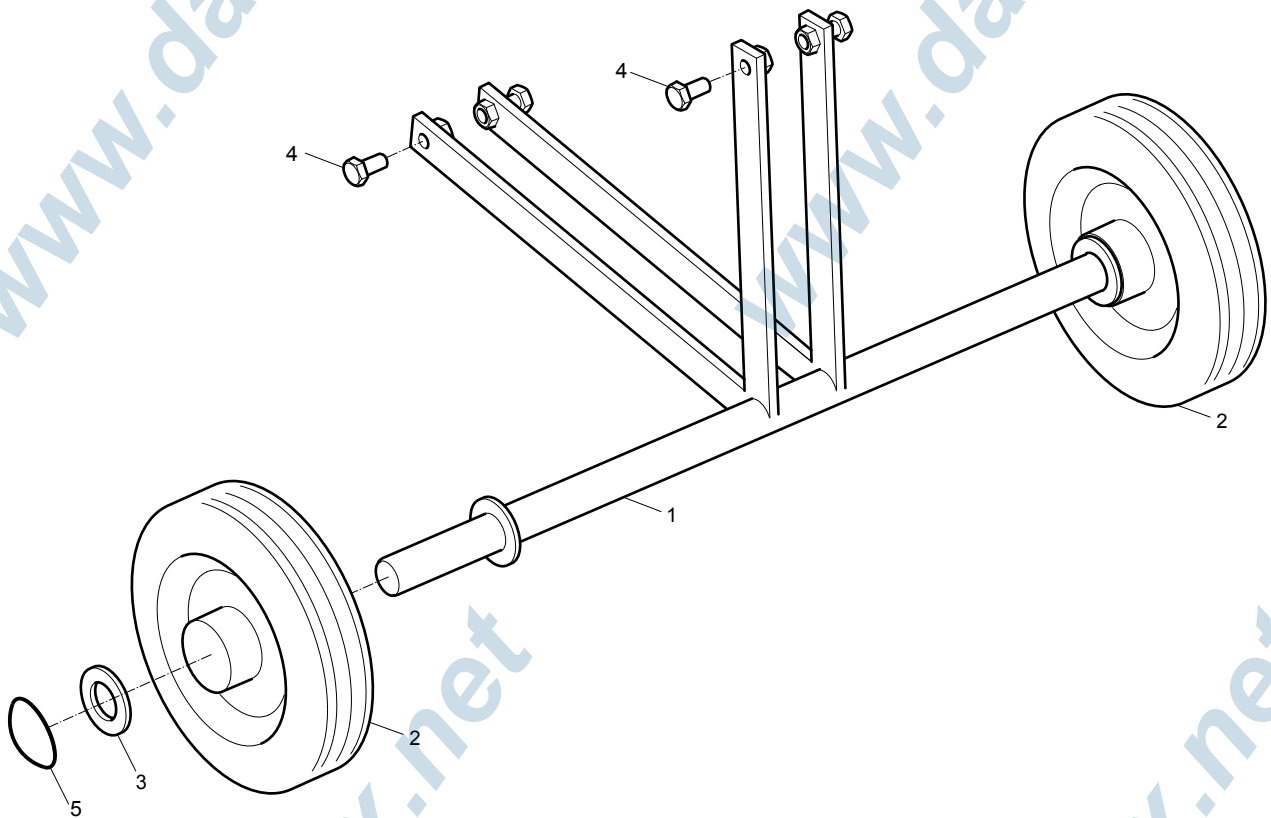

No.	Description	Remark	Quantity	Part number
1	Wheel frame		1	4700 0331 39
2	Wheel		2	4700 0017 55
3	Washer	21 x 37 x 3 mm 0.83 x 1.46 x 0.12 in.	2	-
4	Screw	M8 x 16 mm 8.8	4	-
5	Locking washer		2	3382 0112 02

www.dalmex.net

www.dalmex.net

Kits

Maintenance kit (yearly recommend)

Description	Remark	Quantity	Part number
Maintenance kit		1	3382 1000 18
V-belt		1	4700 0028 26
Magnetic sensor		1	4700 0033 13
Blade adjusting wire		1	4700 0490 00

www.dalmex.net

www.dalmex.net

Wiring diagram

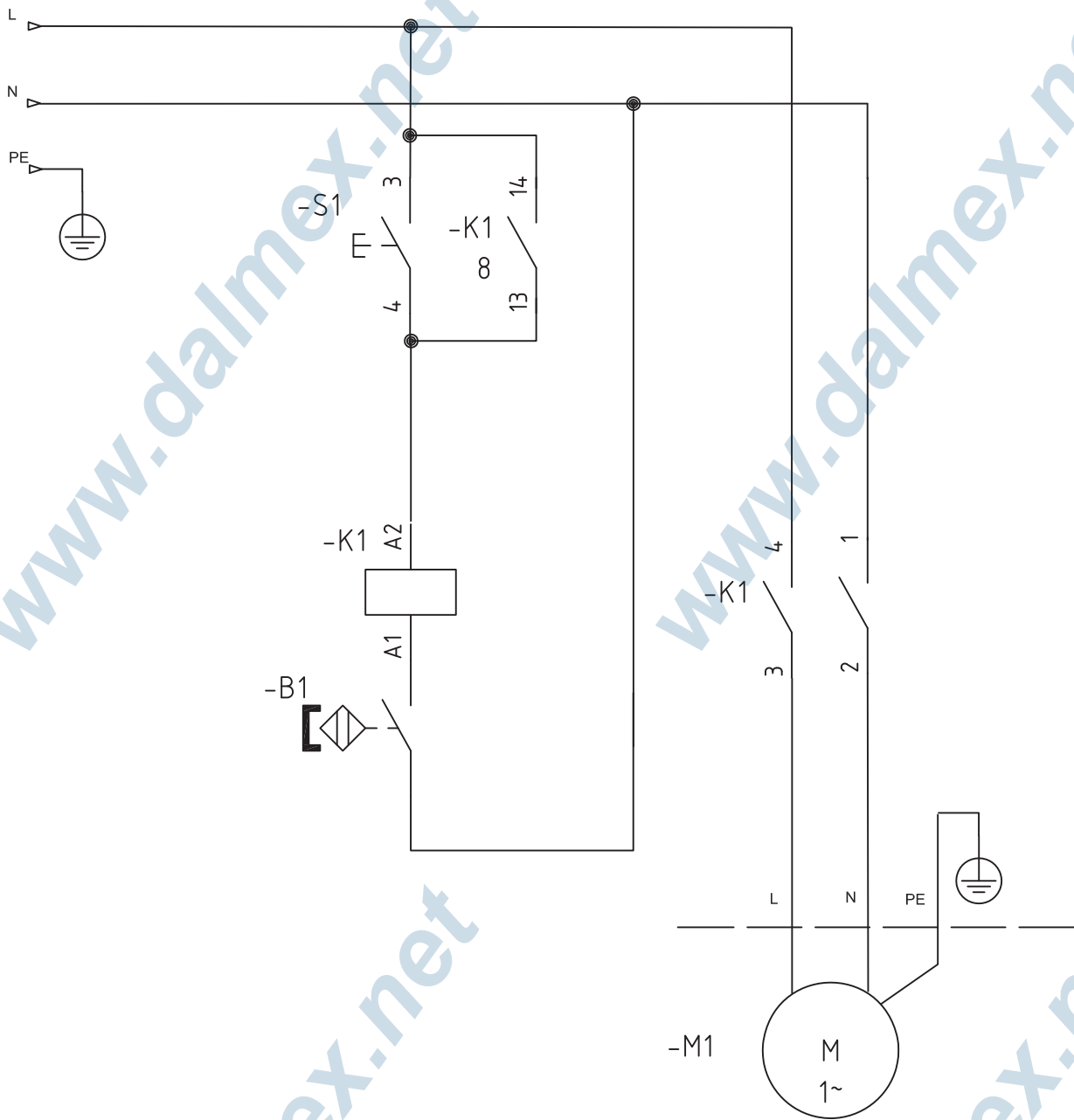



DALMEX

TREMIX®

www.dalmex.net

www.dalmex.net

www.dalmex.net

www.dalmex.net



DALMEX

TREMIX®

www.dalmex.net

www.dalmex.net

www.dalmex.net

www.dalmex.net



DALMEX

TREMIX®

www.dalmex.net

www.dalmex.net

www.dalmex.net

www.dalmex.net



DALMEX

TREMIX®

www.dalmex.net

www.dalmex.net

www.dalmex.net

www.dalmex.net



DALMEX

TREMIX®

www.dalmex.net

www.dalmex.net

www.dalmex.net

www.dalmex.net

Any unauthorized use or copying of the contents or any part thereof is prohibited.
This applies in particular to trademarks, model denominations, part numbers, and drawings.

No. 9800 1342 01 | 2012-05-31

TREMIX®

www.dalmex.net